

Ensure that top centre is properly aligned with floor spring

Fixing Instruction for double action door

Preparatory work

Mill or route out door frame to accept the relevant top centre parts.

Fixing of top centre frame portion

Put end of pivot beam in hole A, B or C, depending on length of throw required for door type.

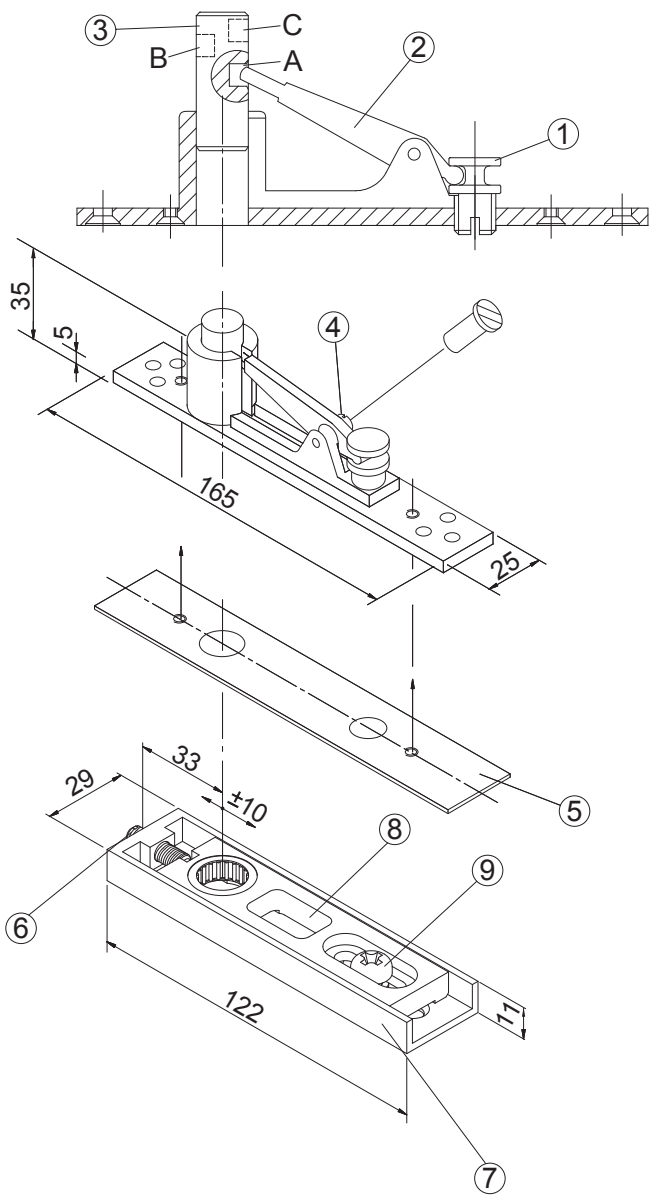

- Turn adjustment screw ① until head is screwed right down onto pivot plate.

- Put other end of pivot beam into adjustment screw ① and place on pivot plate, then secure with screw ④.

- Secure cover plate ⑤ to top centre frame portion by using two (2) M4x7.5 screws provided.

Fixing of top centre door portion

- Insert adjustment screw ⑥ into top centre bar ⑦.

- Insert slide piece ⑧ adjust with screw ⑥ and secure with screw ⑨.

Installation of door

- Offer door leaf onto floor spring and open door slightly.

- Lower pivot into needle bearing in door portion by turning screw ① clockwise.

To raise or lower nose of door, use adjustment screws ⑥ and ⑨. Ensure both are tight before leaving door.