



Raven RP39 Magnetic Astragal Seal - Clear Anodised Aluminium

RP39

PRODUCT OPTIONS

Door Seal Length: 2250mm
2500mm
3000mm

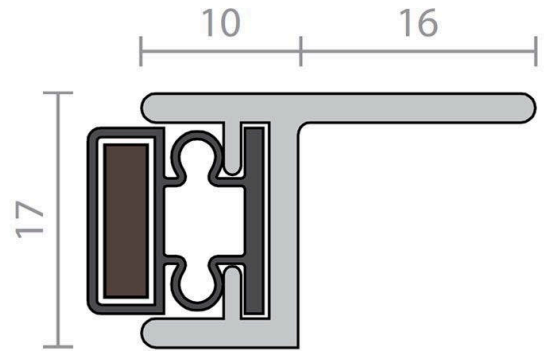

DESCRIPTION

A refrigeration type vinyl magnetic strip in an anodised aluminium housing. RP39 provides a tight seal for steel clad doors and jambs and may be used as a stop. For timber doors, a thin steel strip can be attached to the door face. The magnetic strip has sufficient closing strength that latches may not be required. It can also be used in pairs on meeting stiles of timber doors.

Note: As an astragal seal, RP39 is best suited to infrequent use and door closer hold open applications.

Location: Head, jambs and stiles of single and double butt hinged doors, sliding doors or bulkhead applications.

Min/Max Gap: 4mm to 8mm (meeting stiles).

Finish: Satin clear (silver) anodised aluminium (15micron) or paint at extra cost.

Fixing: Screw fix. Zinc plated, cross recess head S.T. screws supplied. Fixing holes are slotted.

Seal: Black PVC.

Sizes: Available in stock lengths.

Approvals

Fire AUS/NZ: NCC Spec. C3.4. AS1530.4 & AS/NZS 1905.1. NZ BC Compliance Doc C/AS1 6.19.2(a) and App C6.1.1.

UK/EU: Approved Document B. BS 426 Pt. 20 & 22 (similar to BS EN 1634.1).

FRL & FRR-/240/30 and FD240. Fire Approved

Energy NCC Pt. 3.12.3.3 & J3.4.

SPECIFICATION