

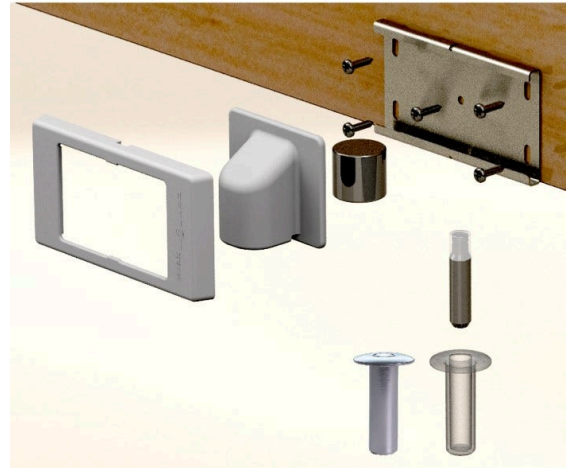

# Fantom Defender Door Stop and Holder - Chrome Plate

SKU FTM-DEF-CHROME

MPNDEFENDER-TRADE-CHROME



## DESCRIPTION

### Fantom Door Stop - Defender - Chrome Plate

The Fantom Defender combines modern aesthetics with reliable security and smooth functionality to provide you with two functional modes. Utilizing rare-Earth technology and a patented sliding face-mount system, the simple foot-activated Fantom Defender allows the door to be opened just enough to see who is on the other side before allowing complete access— protecting you against intruders attempting to enter your home by force. When not being used as a security measure, the Fantom Defender is a functional, hazard-free doorstop used to prevent the door from contacting walls and furniture, or from opening any further than desired. The Defender also features a strong “hold open” function to keep you door held in position when desired.

### Features

Security and Doorstop in 2  
Stops Intruders from forcing the door open  
Eliminates Trip hazard when used as a doorstop

## SPECIFICATION

|                                 |                       |
|---------------------------------|-----------------------|
| <b>MPN</b>                      | DEFENDER-TRADE-CHROME |
| <b>Brand</b>                    | Fantom Hardware       |
| <b>Product Height</b>           | 45.8mm                |
| <b>Product Warranty</b>         | 2 Years               |
| <b>Product Diameter</b>         | 28mm                  |
| <b>Projection or Length</b>     | 15mm                  |
| <b>Product Finish or Colour</b> | Chrome Polish (CP)    |
| <b>Product Material</b>         | Varied Metals         |
| <b>Includes Fixing Screws</b>   | Yes                   |

## ADDITIONAL IMAGES



### Fantom Defender Door Stop and Holder - Chrome Plate

Scan to view online and for additional product information , or call us on **1800 555 600**.

Print Date: 2/5/24

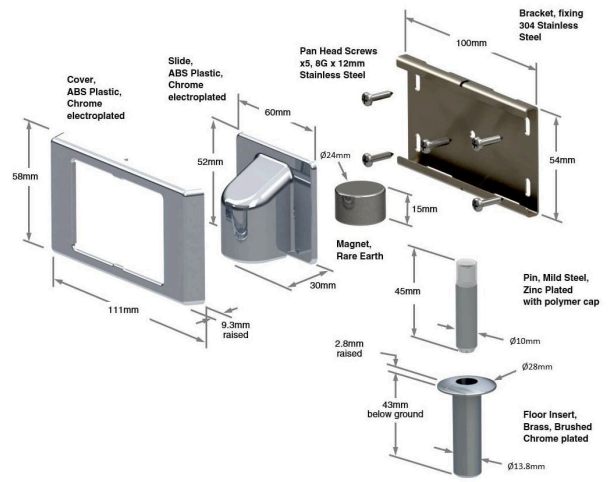
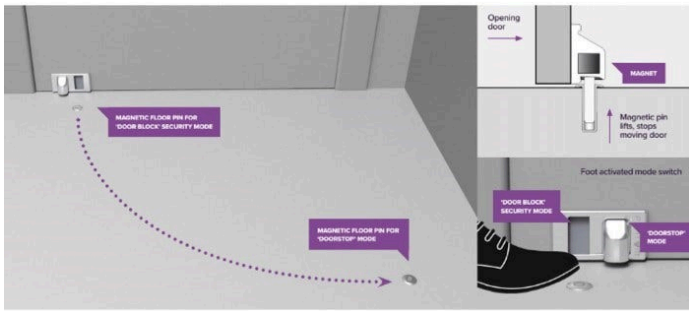

**Fantom Defender Door Stop and Holder - Chrome Plate**  
 Scan to view online and for additional product information , or call us on **1800 555 600**.

Print Date: 2/5/24